

MOBILE (QUEEN MARY) SHELVING UNITS

- ▶ 400 lbs. capacity per shelf
- ▶ Heavy-duty, solid adjustable shelves
- ▶ Smooth solid surface; easy to clean
- ▶ 1/8" Marine edge, contains spills
- ▶ All aluminum – WILL NOT RUST
- ▶ Easy "locking bushing" assembly
- ▶ Ships "knock down" UPS
- ▶ Heavy-duty 5" stem casters – 2 5" Swivel (CHV), 2 5" swivel locking (CHL)

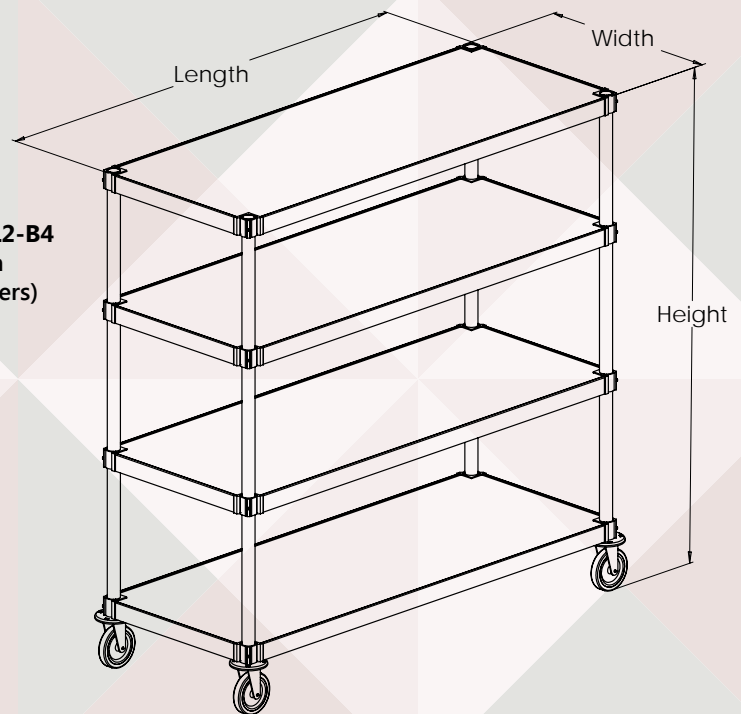

N244860-4-CHL2-B4
(shown with optional bumpers)



Mobile (Queen Mary) Shelving Units

| Model Number | Size W xH x L |
|----------------|-----------------|
| N204836-4-CHL2 | 20" x 54" x 36" |
| N204848-4-CHL2 | 20" x 54" x 48" |
| N204860-4-CHL2 | 20" x 54" x 60" |
| N206036-4-CHL2 | 20" x 66" x 36" |
| N206048-4-CHL2 | 20" x 66" x 48" |
| N206060-4-CHL2 | 20" x 66" x 60" |
| N244836-4-CHL2 | 24" x 54" x 36" |
| N244848-4-CHL2 | 24" x 54" x 48" |
| N244860-4-CHL2 | 24" x 54" x 60" |
| N246036-4-CHL2 | 24" x 66" x 36" |
| N246048-4-CHL2 | 24" x 66" x 48" |
| N246060-4-CHL2 | 24" x 66" x 60" |

Options: CL, CHV, CHL, B – see page 82 for details



Prairie View Industries Food Service

PHONE 800.554.7267 | FAX 402.729.4058 | WEB www.pvifs.com